

# KOMATSU®

## GD705-5

**GD**  
**705**

### HORSEPOWER

Gross: 194 kW 260 HP / 1950 min<sup>-1</sup>

Net: 186 kW 250 HP / 1950 min<sup>-1</sup>

### OPERATING WEIGHT

19300 kg (with ripper 22150 kg)

### BLADE LENGTH

4.32 m



Photos may include optional equipment.

# **WALK-AROUND**





### **PRODUCTIVITY**

- ▮ Long Wheelbase & Short Turning Radius
- ▮ Job Proved Komatsu Power Train
- ▮ Ideal Weight Distribution

### **CONTROL**

- ▮ Outstanding Power Transmitting System

### **COMFORT**

- ▮ Excellent visibility
- ▮ Spacious Interior

### **SERVICEABILITY**

- ▮ Machine Monitoring System
- ▮ Easy Maintenance Design

### **KOMTRAX**

- ▮ Energy Saving Operation Report ▮ Equipment Management Support
- ▮ Optimal Strategy for Efficient Work

### **ECOLOGY & ECONOMY**

- ▮ Engine power mode selection system
- ▮ Circumference dynamic noise

#### **GD705-5**

<b>HORSEPOWER</b>	Gross:	194 kW 260 HP/1950min <sup>-1</sup>
	Net:	186 kW 250 HP/1950min <sup>-1</sup>
<b>OPERATING WEIGHT</b>	19300 kg (with ripper 22150 kg)	
<b>BLADE LENGTH</b>	4.32 m	

# DASH 5 SERIES MOTOR GRADERS



## The Perfect Fit for the Jobsite

Most of motor grader applications requires accuracy and versatility. For that, motor graders should be easy to operate in any situations of work.

To realize this ease of operation, Komatsu Dash 5 Series Motor Graders are totally improved from overview design down to each element.

Our design philosophy contributes to our motor graders fitting in every jobsites from road construction to snow removal, and brings more productivity to every operators from beginner to expert.

## Efficient Large Size Grader

The GD705-5 is designed to perform efficient operation. New Hydraulic variable displacement piston pump for reducing pressure loss, improvements in transmission and axles for improving energy saving, and the sophisticated electronic control of the engine operation to achieve optimal energy efficiency.



---

---

Earthwork amount maximum **5.0%** UP (P Mode)

---

---

Fuel consumption maximum

**5.0%** reduction (P Mode)  
**15.0%** reduction (E Mode)

---

---

\* Compared with the GD705A-4. Fuel consumption varies depending on job conditions.

**PRODUCTIVITY****Long Wheelbase & Short Turning Radius**

The long wheelbase enables high leveling performance with a long blade and easier to set the blade position. Long wheelbase also contributes to expanding blade reach in combination with large articulation angle. Additionally the minimum turning radius still short with wide steering angle, serves high maneuverability.

**Optimized Hydraulic & Cooling System****Control valve**

Komatsu Multifunctional Control Valve with Closed Load Sensing System (CLSS) Hydraulic System enable the constant cylinder speed, excellent multifunctional operation ability and fine control.

**1) Low operating effort**

Implement controls are designed to reduce operator fatigue. They feature short lever throws and effort in both directions. Properly spaced control levers and short lever throws allow the operator to use multiple controls with one hand.

**2) Balanced flow**

When the operator uses several controls at the same time, flow is proportional to ensure several implements can operate simultaneously.

**3) Constant implement speed**

Implement speed is constant regardless of engine speed because of the large pump output and proportional flow control function.

**Power on demand**

Normally, the variable displacement pump idles at low output. When it senses a load requirement, the pump supplies quick flow and pressure to match the demand.

The result is less hydraulic system heat, quick response and lower fuel consumption.

**Hydraulic Cooling fan**

The newly designed cooling fan eliminates excessive cooling capacity by controlling air flow rate according to work load.



## Outstanding Power Transmitting System

The GD705-5 features Lock-up Torque Converter Transmission for pursuing ease of operation.

This unique system provides both efficiency of direct drive and controllability of Torque Converter drive.

With this outstanding power transmitting system, the GD705-5 delivers advanced productivity in any applications from fine grading to heavy grading.

## Torque Converter Features

### High controllability

- Eliminates engine stalling and inching pedal operation
- Smooth starting, good controllability in fine grading
- Easy travelling, automatic gear shifting
- Reduce excessive tire slipping

### Torque multiplication

- Multiply over twice torque, provides much torque in heavy grading, ditching and ripping
- Stable engine speed, reduce shift changing during road maintenance and snow removal

### Lock-up function

- Prevents loss of efficiency



## Transmission Mode Selection

There is two transmission mode to enhance productivity. With the push of a button, transmission mode is selected to fit in working condition and preference of operators.

### Auto mode

Drive with Torque Converter in all shift position. This mode maximizes Torque Converter benefits. Lock-up will works in F5-F8 and R3-R4 position. Shifting F8 position serves automatic shifting through F4-F8 in responsible to machine speed.

### Manual mode

Works like a same way as conventional power shift, by engaging lock up clutch with all gears. This mode maximizes efficiency of direct shifting. In reverse travelling, works same way as Auto mode, serves less shift lever operation frequency.

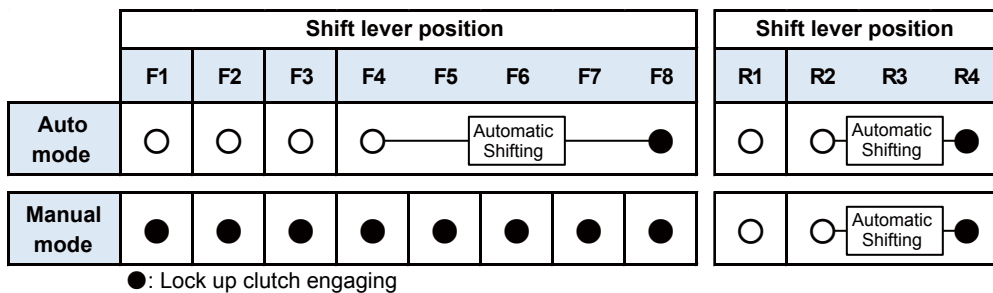

## Anti Stall

Prevents engine stalling while Lock up by automatically disengaging the lock up clutch and shifting to torque converter state. Torque converter provides much torque to continue to work as it is, never needs to restart the engine and shift the gear.

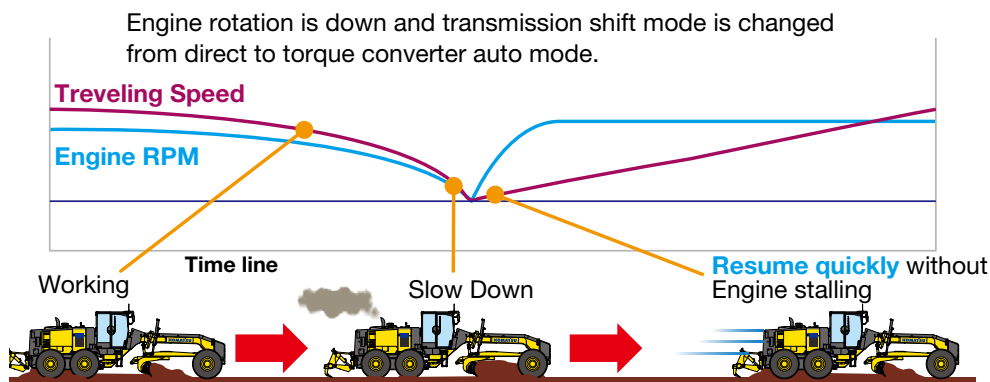

## Creep Mode

Torque converter transmission introduces Creep Mode which provides constant low speed without acceleration and brake control. Optimized machine speed and great stability of torque converter boosts up precise control during fine grading.

## Power Train Protection

Electronic Over-Speed Protection Prevents downshifting until reducing the travel speed to the safe range of shift changing. FR Inhibitor restricts excessive shuttle shifting at high traveling speed.

## Reduce Shift Shock for Driving Comfort

Torque Converter allows to absorb torque fluctuation of the engine. Even in shifting the gear during Lock up, torque converter temporally absorb shift shock and contributes high driving comfort.

# COMFORT



## Excellent Visibility

Excellent visibility by hexangular cab with front Y shape pillar and rear layout side pillar boost operator's confidence and productivity in all grader applications. Well-positioned blade linkage provides an unobstructed view of the moldboard and front tires. The tapered engine hood provides good visibility to the rear of the machine, especially the rear ripper.

## ROPS cab



Low profile cab is designed to ensure ROPS/FOPS (ISO 3471/ISO 3449) certification.

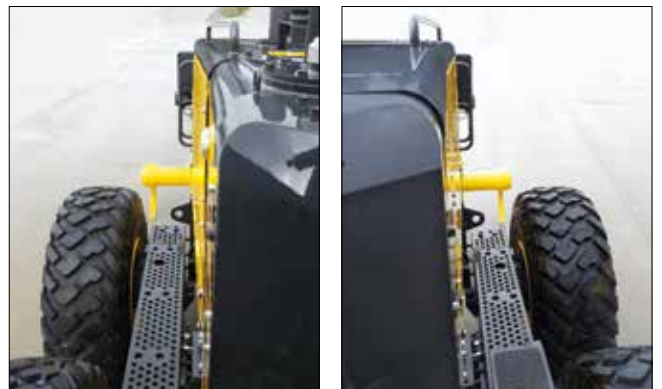

Rear (ripper) view from the cab



## Spacious Interior

### Low noise

New hydraulically driven fan and redesigned layout of the cooling system achieve a low noise level.

**Operator's ear dynamic noise level (ISO6396) 78 dB (A)**

### Suspension seat

The suspension, fabric covered seat which is adjustable to the operator's weight is provided as standard.

The suspension seat dampens vibrations transmitted from the machine and reduces operator fatigue.

The seat features fold-up armrests and a retractable seat belt.



### Air conditioner

Well-positioned air conditioning vents keep the operator comfortable through a wide range of outside conditions.



### Electric throttle control

The RPM mode select switch allows the operator to perfectly match the working condition by selecting between three modes: Auto, Off and Manual. The engine speed set by throttle switch is temporarily cancelled when operating the brake/acceleration pedal at Auto mode.



### Storage Space

The cab includes built-in storage space for personal items such as a lunch box, coffee cup, and a coat hook.



### Adopted DC12V electrical outlet (optional)

12 V DC outlets is included in the operator's cab.

### Adjustable control console

The control console is adjustable backward and forward to facilitate entry and exit from the cab. The steering wheel also tilts to the operators preference.

## Machine Monitoring System

The machine monitor displays various machine information and allows for various settings of the machine. Displays maintenance information, operation records, etc. By using the switch panel, you can display various user menus on the Liquid Crystal Display (LCD) unit screen and perform the settings of the machine.

### • Clear Character Display

During normal operation, the service meter/odometer is displayed in this area. If an abnormality or machine overload occurs, or if machine maintenance and inspection are required, action codes appear on the display to allow the operator to take appropriate action.



- ① Gear position
- ② Speed meter
- ③ ECO indicator
- ④ Power mode indicator
- ⑤ Character display
  - Service meter
  - Odometer
  - Maintenance information
  - Error code
  - Fuel consumption information

## Easy Maintenance Design

### Accessibility to service areas

- Easy and more safety refueling from the ground
- Large hinged service door serves wide inspection area
- Service meter is integrated with the machine monitor
- Distinguishable fuse panel in the cab
- Tandem oil check points is easy to access
- Spin-on filters for quick replacing
- Oil drains located near ground



Ground refueling

### Power train components

With a modular design, you can remove the engine, transmission or final drives independently for quick service.

### Disconnect switch

For inspection and maintenance, the batteries can be disconnected with this switch when repairing the machine or checking batteries.



Tool box

**KOMTRAX**

*The Komatsu remote monitoring and management technology provides insightful data about your equipment and fleet in user-friendly format.*

**Energy Saving Operation Report**

KOMTRAX delivers the energy-saving operation report based on the operating information such as fuel consumption, load summary and idling time, which helps you efficiently run a business.

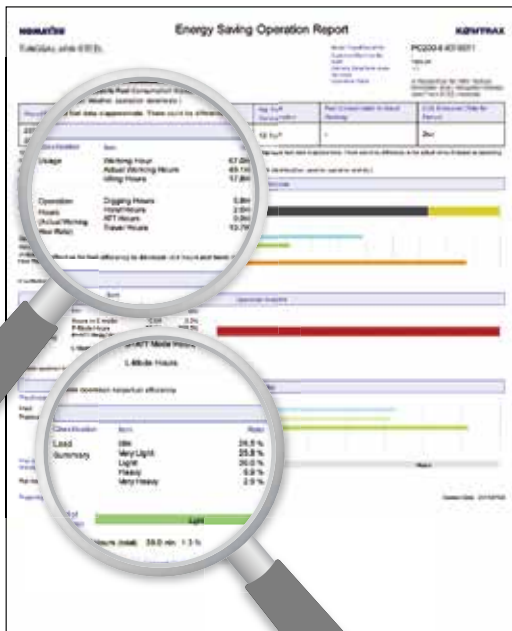

This report image is an example of hydraulic excavator

**Equipment Management Support**

Through the web application, a variety of search parameters are available to quickly find information about specific machines based on key factors. Moreover, KOMTRAX finds out machines with problems from your fleet and shows you through an optimal interface.



The report contents and data depend on the machine model.

**Optimal Strategy for Efficient Work**

The detailed information that KOMTRAX puts at your fingertips helps you manage your fleet conveniently on the web anytime, anywhere. It gives you the power to make better daily and long-term strategic decisions.





## Komatsu technology



Komatsu uniquely develops all major components including total control system, like engines, electronics, and hydraulic components.

With this “Komatsu technology” and continuous customer feedback, Komatsu has been achieving great advancements of technology.

This resulted in new generation of high performance and environmentally friendly products.

### High performance engine

Powerful turbocharged and air-to-air aftercooled Komatsu SAA6D114E-3 engine provides 186 kW 250 HP. This engine realizes high power with low fuel consumption by Common Rail Injection system (CRI), and thus it delivers higher work speeds with high horsepower. In addition, high torque at low speed, impressive acceleration, and low fuel consumption ensure maximum productivity.

This engine is U.S. EPA Tier 3 and EU Stage 3A emissions equivalent.

### Engine power mode selection system

The system allows selection of the appropriate mode between two modes E or P mode according to each working condition. The mode is easily selected with a switch in the operator's cab.

#### • P mode

Greater productivity can be attained by taking full advantage of high output power. It is appropriate for job sites where the motor grader meets high resistance.

#### • E mode

This mode is selected for maximum economy and lighter work applications. This feature provides the appropriate power and better fuel consumption.



unit: kW(HP)

	P mode	E mode
F1	150 (201)	120 (161)
F2		
F3	165 (221)	150 (201)
F4		
F5		
F6	186 (250)	165 (221)
F7		
F8		
R1	150 (201)	120 (161)
R2		
R3	165 (221)	150 (201)
R4		

**Circumference dynamic noise**

The dynamic circumference noise is lowered significantly to 7dB(A) compared with the conventional GD705A-4 by various kind of countermeasures like the hydraulic driven cooling fan ,the variable displacement pump and etc.

---

**Circumference dynamic noise level (ISO6395) 109 dB (A)**

---



Hydraulic driven cooling fan

**Double seal cylinder (Blade side shift cylinder)**

A double-seal design is used for the blade side shift cylinder, which is installed near the ground, and thus susceptible to damage by dirt.

Environmentally friendly by preventing oil leakage from the cylinder.

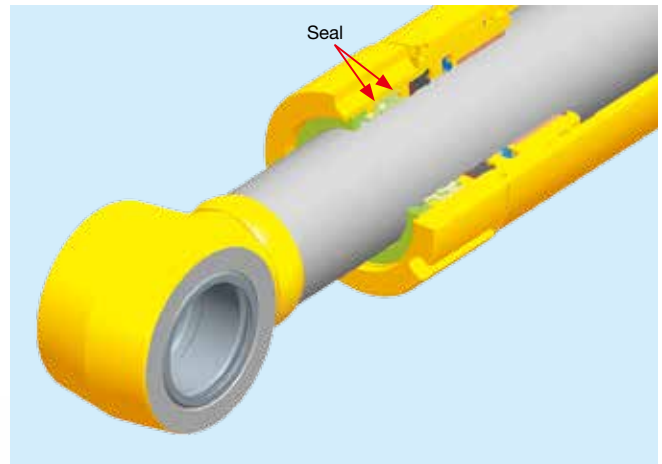



## Komatsu Genuine Work Equipment

### Moldboard Options

Installs Side Edge as standard. Flat moldboard surface facilitates smooth rolling off of material. Optional Overlay Endbit surely protects the side end of the moldboard.

### Front Blade

The front blade is a front mounted equipment used for spreading materials such as gravel piles or blading at the front of the machine where is difficult to access with the moldboard.

### Ripper and Scarifier

Digs up hard material cannot be removed by the moldboard. The scarifier can accommodate up to 9 teeth, the ripper also accommodate up to 5 shanks.



**KOMATSU TOTAL SUPPORT****Komatsu Total Support**

To keep your machine available and minimize operation cost when you need it, Komatsu Distributor is ready to provide variety of support before and after procuring the machine.

**Fleet recommendation**

Komatsu Distributor can study the customer's job site and provide the most optimum fleet recommendation with detailed information to meet all of your application needs when you are considering to buy new machines or replace the existing ones from Komatsu.

**Product support**

Komatsu Distributor gives the proactive support and secures the quality of the machinery that will be delivered.

**Parts availability**

Komatsu Distributor is available for emergency inquiry by the customers for genuine, quality guaranteed Komatsu parts.

**Technical support**

Komatsu product support service (Technical support) are designed to help customer. Komatsu Distributor offers a variety of effective services how much Komatsu is dedicated to the maintenance and support of Komatsu machine.

- Preventive Maintenance (PM) clinic
- Oil & Wear analysis program

**Repair & maintenance service**

Komatsu Distributor offers quality repair and maintenance service to the customer, utilizing and promoting Komatsu developed programs.

**Komatsu Reman (Remanufactured) components**

Komatsu Reman products are the result of the implementation of the Komatsu global policy which establishes and agrees to reduce the owning, operating and total Life Cycle Costs (LCC) to Komatsu's customer through high quality, prompt delivery and competitively priced in own remanufactured products (QDC).



# SPECIFICATIONS



## ENGINE

Model . . . . . KOMATSU SAA6D114E-3  
 Type . . . . . Water-cooled, 4-cycle, direct injection  
 Aspiration . . . . . Turbocharged and air to air aftercooled  
 Number of cylinders . . . . . 6  
 Bore . . . . . 114 mm  
 Stroke . . . . . 135 mm  
 Piston displacement . . . . . 8.27 L  
 Gross horsepower (Manual mode)  
 P-mode  
 Gear 1-2 . . . . . 158 kW 212 HP/1950 min<sup>-1</sup>  
 Gear 3-5 . . . . . 173 kW 232 HP/1950 min<sup>-1</sup>  
 Gear 6-8 . . . . . 194 kW 260 HP/1950 min<sup>-1</sup>  
 E-mode  
 Gear 1-2 . . . . . 128 kW 172 HP/1950 min<sup>-1</sup>  
 Gear 3-5 . . . . . 158 kW 212 HP/1950 min<sup>-1</sup>  
 Gear 6-8 . . . . . 173 kW 232 HP/1950 min<sup>-1</sup>  
 Net horsepower (Manual mode)  
 P-mode  
 Gear 1-2 . . . . . 150 kW 201 HP/1950 min<sup>-1</sup>  
 Gear 3-5 . . . . . 165 kW 221 HP/1950 min<sup>-1</sup>  
 Gear 6-8 . . . . . 186 kW 250 HP/1950 min<sup>-1</sup>  
 E-mode  
 Gear 1-2 . . . . . 120 kW 161 HP/1950 min<sup>-1</sup>  
 Gear 3-5 . . . . . 150 kW 201 HP/1950 min<sup>-1</sup>  
 Gear 6-8 . . . . . 165 kW 221 HP/1950 min<sup>-1</sup>  
 Maximum torque . . . . . 1130 Nm 115 kgf-m/1450 min<sup>-1</sup>  
 Torque rise . . . . . 19 %  
 Fan speed . . . . . Max. 1700 min<sup>-1</sup>  
 Air cleaner . . . . . 2-stage, dry-type  
 U.S. EPA Tier 3 and EU Stage 3A emissions equivalent.



## TRANSMISSION AND TORQUE CONVERTER

Full power shift transmission with torque converter and lock-up.

**Speeds** (at rated engine speed)

Gear	Forward	Reverse
1st	4.0 km/h	4.5 km/h
2nd	5.6 km/h	8.8 km/h
3rd	7.7 km/h	17.4 km/h
4th	10.9 km/h	34.1 km/h
5th	15.3 km/h	—
6th	21.6 km/h	—
7th	30.0 km/h	—
8th	42.5 km/h	—

Maximum travel speed at engine high idle is 47.9 km/h.



## TANDEM DRIVE

Oscillating welded box section . . . . . 567 mm x 226 mm  
 Side wall thickness: Inner . . . . . 22 mm  
 Outer . . . . . 19 mm  
 Wheel axle spacing . . . . . 1680 mm  
 Tandem oscillation . . . . . 15° forward, 15° reverse



## FRONT AXLE

Type . . . . . Solid bar construction welded steel sections  
 Ground clearance at pivot . . . . . 670 mm  
 Wheel lean angle, right or left . . . . . 15°  
 Oscillation, total . . . . . 32°



## REAR AXLE

Alloy steel, heat treated, full floating axle with lock/unlock differential.



## STEERING

Hydraulic power steering providing stopped engine steering meeting ISO 5010.  
 Minimum turning radius . . . . . 7.6 m  
 Maximum steering range, right or left . . . . . 50°  
 Articulation . . . . . 27°



## BRAKES

Service brake . . . . Foot operated, sealed oil disc brakes, hydraulically actuated on four tandem wheels.  
 Parking brake . . . . Manually actuated, spring applied, hydraulically released caliper.



## FRAME

Front Frame Structure  
 Height . . . . . 339 mm  
 Width . . . . . 300 mm  
 Side . . . . . 14 mm  
 Upper, Lower . . . . . 22/25 mm



## DRAWBAR

A-shaped, u-section press formed and welded construction for maximum strength with a replaceable drawbar ball.  
 Drawbar frame . . . . . 235 mm x 25 mm



## CIRCLE

Single piece rolled ring forging. Six circle support shoes with replaceable wear surface. Circle teeth hardened on front 180° of circle.  
 Diameter (outside) . . . . . 1550 mm  
 Circle reversing control hydraulic rotation . . . . . 360°





**MOLDBOARD**

Hydraulic power shift fabricated from high carbon steel. Includes replaceable metal wear inserts, cutting edge and end bits. Cutting edge and end bits are hardened.

Dimensions . . . . .	4320 mm x 700 mm x 25 mm
Arc radius . . . . .	414 mm
Cutting edge . . . . .	.203 mm x 16 mm
Replaceable/Reversible side edges . . . . .	280 mm x 620 mm x 13 mm
Blade pull	
Base GVW . . . . .	11040 kgf
With scarifier GVW . . . . .	11125 kgf
With ripper GVW . . . . .	12880 kgf
Blade down pressure	
Base GVW . . . . .	.9120 kgf
With scarifier GVW . . . . .	10565 kgf
With ripper GVW . . . . .	10030 kgf



**BLADE RANGE**

Circle center shift:	
Right . . . . .	585 mm
Left . . . . .	545 mm
Moldboard side shift:	
Right . . . . .	965 mm
Left . . . . .	965 mm
Maximum shoulder reach outside rear tires (frame straight)	
Right . . . . .	2360 mm
Left . . . . .	2290 mm
Maximum lift above ground . . . . .	450 mm
Maximum cutting depth . . . . .	710 mm
Maximum blade angle, right or left . . . . .	90°
Blade tip angle . . . . .	45° forward, 7° backward



**HYDRAULICS**

Load-sensing closed center hydraulics with variable displacement piston pump. Short stroke/low effort direct acting control valves with preselected maximum flow setting to each function. Double acting anti-drift check valves on blade lift, tip, circle shift, articulation, and leaning wheels.

Output (at engine rated rpm) . . . . .	165L/min
Standby pressure . . . . .	3.4 MPa 35 kgf/cm <sup>2</sup>
Maximum system pressure . . . . .	24.5Mpa 250 kgf/cm <sup>2</sup>



**INSTRUMENT**

Electric monitoring system with diagnostics:

Gauges:

Standard . . . . . articulation, engine coolant temperature, fuel level, speed meter, T/M shift indicator, engine tachometer torque converter oil temperature

Warning lights/Indicator:

Standard . . . . . battery charge, brake oil pressure, inching temperature, directional indicator, engine oil pressure, hydraulic oil temperature, heater signal, lift arm lock, parking brake, differential lock, torque converter oil temperature, eco, P mode, rpm set, high beam, working lights

Optional . . . . . blade accumulator



**CAPACITIES (REFILLING)**

Fuel tank . . . . .	408 L
Cooling system . . . . .	24.5 L
Crank case . . . . .	27 L
Transmission . . . . .	62 L
Final drive . . . . .	11.5 L
Tandem housing (each) . . . . .	79 L
Hydraulic system . . . . .	69 L
Circle reverse housing . . . . .	10 L



**OPERATING WEIGHT (APPROXIMATE)**

Includes lubricants, coolant, full fuel tank

Total . . . . .	20275 kg
On rear wheels . . . . .	13800 kg
On front wheels . . . . .	5500 kg

With front mounted scarifier:

Total . . . . .	20275 kg
On rear wheels . . . . .	13905 kg
On front wheels . . . . .	6370 kg

With rear mounted ripper and front push plate:

Total . . . . .	22150 kg
On rear wheels . . . . .	16100 kg
On front wheels . . . . .	6050 kg



**SCARIFIER (OPTIONAL)**

Middle, V-type	
Working width . . . . .	1350 mm
Scarifying depth, maximum . . . . .	210 mm
Scarifier shank holders . . . . .	11
Scarifier shank holders spacing . . . . .	130 mm



**RIPPER (OPTIONAL)**

Ripping depth, maximum . . . . .	380 mm
Ripper shank holders . . . . .	5
Ripper shank holder spacing . . . . .	540 mm
Penetration force . . . . .	11220 kgf
Pry out force . . . . .	26280 kgf
Machine length increase, beam raised . . . . .	870 mm



## DIMENSIONS

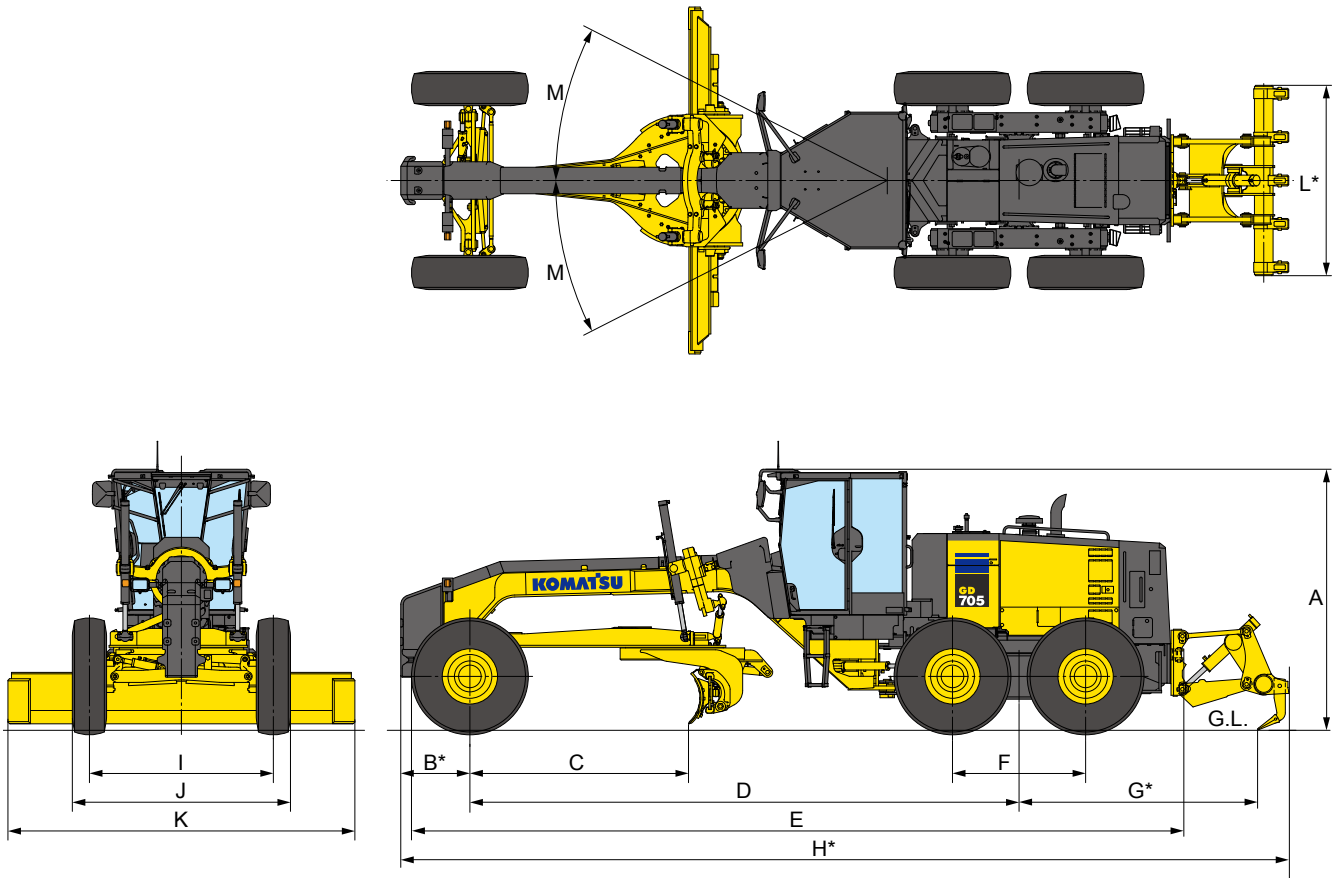

A	Height: Low profile cab	3260 mm
B*	Center of front axle to counterweight (Pusher)	860 mm
C	Cutting edge to center of front axle	2700 mm
D	Wheel base to center of tandem	6800 mm
E	Front tire to rear bumper	9600 mm
F	Tandem wheelbase	1680 mm
G*	Center of tandem to back of ripper	2955 mm
H*	Overall length	11050 mm
I	Track of gauge	2290 mm
J	Width of tires	2790 mm
K	Width of standard moldboard	4320 mm
L*	Ripper beam width	2366 mm
M	Articulation, left or right	27°

\*optional



## WHEELS, FRONT AND REAR

Tire	Rim size	Rim structure
16.00-24	10"	Multi-piece
20.5R25	17"	Multi-piece

**STANDARD EQUIPMENT****Engine and Related Items**

- Air intake extension
- Double element air cleaner and dust indicator.
- Engine: Komatsu SAA6D114E-3, turbocharged and air-to-air aftercooled, standard Variable Horsepower Control, 201-250 net horsepower
- Fuel prefilter
- Hood-sides for engine compartment

**Electrical Systems**

- Alarm, back-up
- Alternator, 24V/60A
- Battery, 2 x 12V/140Ah
- Dome light, cab
- Horn, electric
- Indicators: parking brake, differential lock, lift arm lock, high beam, eco, engine P mode, rpm set, engine oil pressure, battery charge, brake oil pressure, differential oil temperature
- Lights: back-up, stop, tail, directional, headlights (2 halogen type, front bar mounted)
- Speedometer

**Operator Environment**

- Air conditioner (R134a)
- Cab: low profile enclosed ROPS/FOPS (ISO 3471/ISO 3449) with safety tinted glass windows with wiper and washer
- Cigarette lighter and ashtray
- Console, adjustable with instrument panel monitoring system
- Mirrors: interior cab, right and left exterior mirrors
- Sound suppression, cab and floor mat
- Suspension seat, deluxe adjustable cloth with retractable seat belt
- Wipers, front, doors, and rear

**Power Train**

- Axle, rear full floating, planetary type
- Brake, parking, spring applied, hydraulic release, disc type
- Differential, lock/unlock
- Dual mode Transmission (F8-R4) power shift, direct drive and torque converter with auto shift, engine stall prevention function
- Service brakes, fully hydraulic wet disc

**Work Equipment and Hydraulics**

- 9 section hydraulic control valve
- Circle, drawbar mounted, 360° rotation hydraulic blade lift and circle side shift
- Circle slip clutch
- Hydraulic system, closed center, load sensing
- Moldboard: 4320 mm x 700 mm x 25 mm with replaceable end bits, through-hardened cutting edges 203 mm x 16 mm, hydraulic blade side shift and hydraulic tilt with anti-drift check valves. Maximum moldboard angle position 90° right & left
- Steering, full hydraulic with tilt steering wheel plus leaning front wheels and frame articulation w/anti-drift check valves

**Other Standard Equipment**

- Battery disconnect switch
- Fuel tank, ground level access
- General toolkit
- Painting, Komatsu standard color scheme
- Steps and handrails, rear, right, and left side
- Tool box with lock
- Vandalism protection includes lockable access to fuel tank, battery cover, and engine side covers

**OPTIONAL EQUIPMENT**

- 10 section hydraulic control valve
- 12V (10A) power port
- Accumulators, anti-shock for blade lift
- Alternator, 24V/90A
- AM/FM radio
- Cab mount work lamps (4)
- Extinguisher

- Fog light (front bar mounted)
- Pre-cleaner
- Pusher plate, additional
- Rear under view mirror
- Ripper, assembly, rear mounted
- Ripper shanks and points, 2 additional
- Scarifier, assembly, 11-shank type

- Starter, 11 kW
- Transmission under guard
- Warning light, amber colored rotating beacon, cab roof mounted
- Work lamps: front (4), rear (2)

