

KOMATSU

CX50

3.5 / 4.0
4.5 / 5.0 ton

Series

DIESEL & GASOLINE FORKLIFT TRUCKS

EPA Tier 3 / EU Stage IIIA Emission Compliant



"Reducing Total Operating Costs" with Komatsu Innovative Technologies

The fusion of advanced engines and Komatsu's unique hydraulic system enables the new CX50 series to achieve a significant reduction in the total operation costs and facilitates superior work performance. Our innovative machines challenge the conventional concept of the forklift.

Diesel Engine Truck

An optimum engine achieves low fuel consumption and high performance.

Gasoline Engine Truck

A fully electronically controlled engine with a 3-way catalytic system conforms to the latest emission regulations.

Komatsu's Hydraulic System and the NEW Diesel Engine reduce the Fuel Consumption



In order to minimize hydraulic loss and reduce the engine load, the new CX50 Series adopts the CLSS hydraulic system, a proven technology of Komatsu construction machines. The compact 3.3-liter engine features superior performance and achieves up to 20% less fuel consumption.

The "CLSS" contributes to Low Fuel Consumption and High Productivity

The Hydraulic load is automatically detected and only the appropriate amount of oil is supplied via a variable displacement pump. This system eliminates the loss of hydraulic oil and reduces the engine load.

Fuel Consumption
Max. 20% saving

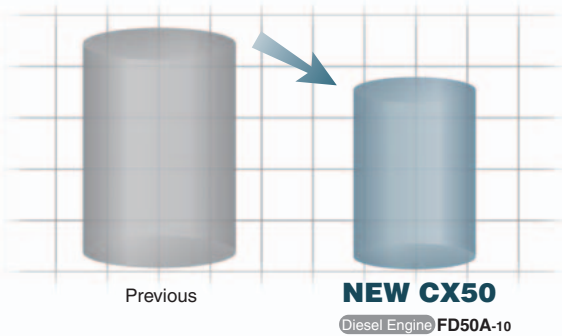

Komatsu tested data, comparison with FD50A-8 model. The results may vary depending on conditions.

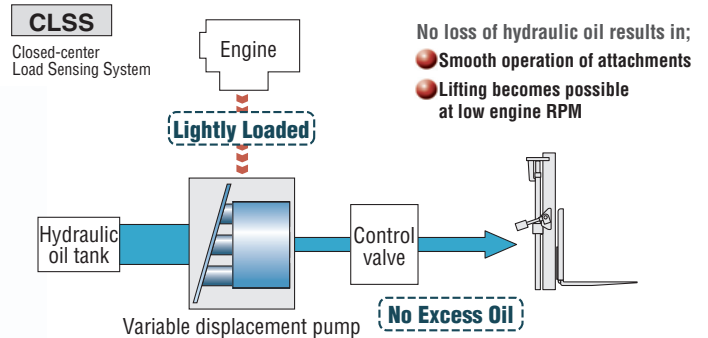

Previous hydraulic system
Fixed amount of oil is supplied from the gear pump and excess oil is returned to the hydraulic oil tank. This resulted in increased engine load.

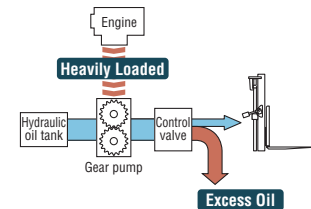

Greatly Reduced Total Operating Costs (Diesel)

The sealed wet disc brakes can withstand about 10,000* hours operation without maintenance and eliminating frequent brake shoes replacements. The engine oil replacement interval has been extended for 300 hours, which reduces oil costs. The reduced maintenance costs and significant fuel saving provide a total operating cost reduction of about 14% over eight years of usage. *A periodical check and oil replacement are necessary. Komatsu genuine engine oil is recommended.

Running cost (Accumulated costs for 8 years)

Assuming FD50A-8 as 100%;

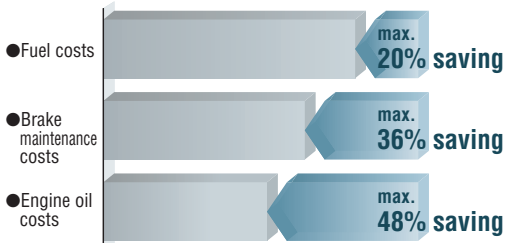

Total operating cost (*Image)

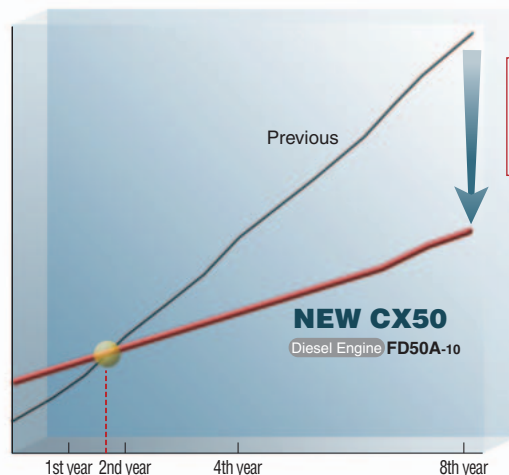

Total operating cost
Approx. 14% saving
(8 years)

Komatsu tested data, Comparison with FD50A-8 model. Operation hours: 5 h/day, 25 days/month (Total: Approx. 1500 h/year). Maintenance intervals to manufacturer's recommendation. Cost calculation is based on Japanese market price. The results may vary depending on conditions.

The Advanced Technology offers Reduced CO₂ Emissions (Diesel)

The diesel models feature the SAA4D95LE-5-A engine in combination with the efficient CLSS hydraulic system, enabling them to reduce annual CO₂ emissions by about 6.5 tons.

Annual CO₂ emissions
About **6.5 tons reduction**

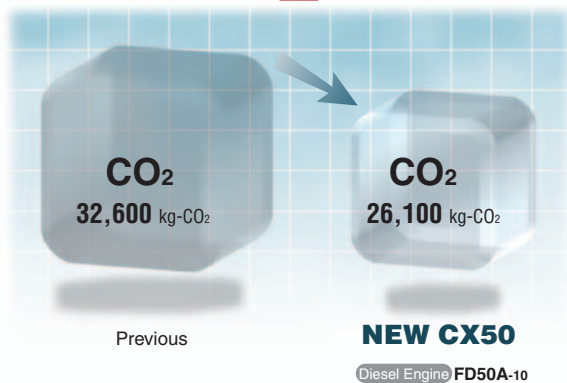

Komatsu tested data, Comparison with FD50A-8 model.
The CO₂ emission coefficient is given in the Common Guidelines of the Japanese METI and MLIT (April 2006).
The results may vary depending on conditions.

An Advanced Diesel Engine conforms to the Latest Emission Regulations

Low fuel consumption and low environmental impact are enabled by elimination of excess combustion and the use of the combined technologies of the high pressure common rail system, electronic control system, new combustion system and air to air charge air cooling system.

EPA Tier 3 / EU Stage IIIA Emission Compliant

ecot3
ecology & economy - technology 3

SAA4D95LE-5-A

Displacement:
3,260 cm³
Rated Output:
59.7 kW @ 2,400 min⁻¹
Maximum Torque:
321 Nm @ 1,600 min⁻¹



Gasoline Engine with a 3-Way Catalytic System

An electronic controlled engine with a 3-way catalytic system ensures a clean workplace.

EPA and CARB Tier 2 Emission Compliant

EBT-GK45-1A*

Displacement:
4,451 cm³
Rated Output:
62.5 kW @ 2,400 min⁻¹
Maximum Torque:
272 Nm @ 1,600 min⁻¹

* EBT-GK45-1A for Gasoline.



Superior "Productivity" and "Reliability" satisfy demanding operations



Durable Wet Disc Brakes to withstand Severe Conditions

The wet disc brake is sealed with oil to block dust penetration, providing durable, water resistant and fade resistant characteristics. Smooth, stable braking provides "Productivity" and "Reliability" in demanding operation.



A Cooling System to achieve Increased Braking Stability

The oil in the wet disc brake system is circulated through the brake oil cooler. This mechanism ensures stable braking under a heavy work load and prevents deterioration of the braking force due to raised oil temperatures.

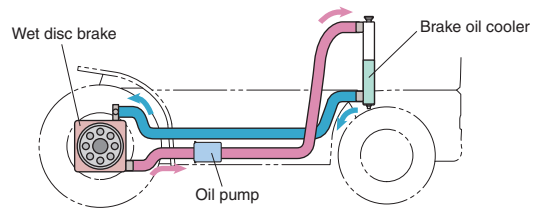

A Cushion Valve improves the Brake Feeling

Komatsu's unique cushion valve enables a controlled braking force that precisely reflects the pressure on the brake pedal. The braking behavior is thus improved.

- **Steady breaking is always achieved.**
- **Overheating of the brakes is prevented.**
- **Rough stopping is prevented when braking.**
- **Downtime and maintenance costs are reduced.**

First-class Productivity is achieved

First-class Cycle Time

The diesel models adopt a compact 3.3-liter engine with the advanced CLSS hydraulic system to achieve high productivity and a first class cycle time. The gasoline engine model also achieves a superior cycle.

- **The NEW CX50 Series achieves high productivity equivalent to the previous CX Series.**

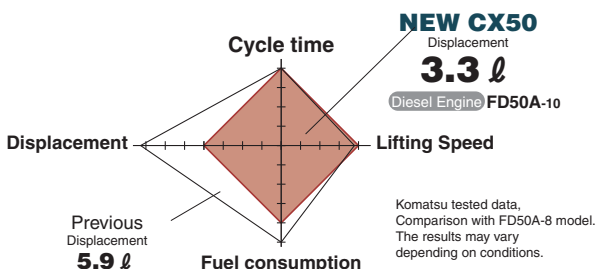

● Lifting Speed (Loaded)

Diesel Engine FD50A-10

470 mm/s

Gasoline Engine FG50A-10

440 mm/s

● Traveling Speed (Unloaded)

Diesel Engine FD50A-10

25.0 km/h

Gasoline Engine FG50A-10

24.5 km/h

The CLSS enables Lifting at Low Engine RPMs

The CLSS makes it possible to lift the load for fine height adjustment without increasing the engine speed.

Reduced engine RPM in the following cases:

- **Fine adjustment of fork height**
- **Lifting fork tips before starting**
- **Fine adjustment for side shifting**

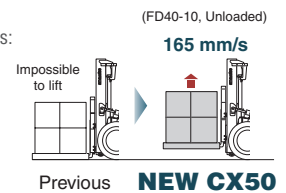

The CLSS enables advantages such as:

- **Smooth traveling during hydraulic operation**
- **Superior productivity is also featured when fitted with attachments**
- **Fuel consumption reduction up to 20% (Diesel)**

Fully Hydrostatic Power Steering for Superb Maneuver

The FHPS (Fully Hydrostatic Power Steering) mechanism facilitates fully stationary steering as well as switchback operations using the small diameter steering wheel. The system has a superior response capability so that the operator can pick up or place cargo flexibly even in a narrow space. In addition, steering knob synchronizer function is available.

Excellent Durability for Demanding Work

Rugged Design with High Rigidity

The high rigidity mast, frame, front and rear axles ensure outstanding reliability even when performing heavy-duty work.

[Mast]

A heavy mast rail profile for excellent rigidity.

[Frame]

Increased thickness of the counterweight mounting section.

[Front axle]

The proven design of the Komatsu wheel loaders is adopted.

[Rear axle]

The durability of the Power Steering cylinders is improved.

Improved Reliabilities for the Hydraulic and Electrical Systems

The main hydraulic pipe connectors are face-sealed using O-rings. Waterproof connectors are provided to the main harnesses and the system controller in order to provide higher resistance to water and dust. Hydraulic and electrical piping systems are in separate configurations to improve the reliability and servicing.

Engine Protection for Maintaining the Engine in Top Condition

The electronic engine controls upgrade the performance of the engine protection (fail-safe functions).

- **Trouble diagnosis:**
Engine malfunctions are automatically detected and an alarm lamp blinks.
- **Overheating prevention (Diesel):**
The engine output and RPMs are reduced when the coolant temperature is high.
- **Automatic engine warm-up (Diesel):**
The RPMs are accelerated to warm up the engine at low temperatures.
- **Automatic air pre-heating (Diesel):**
The engine is automatically pre-heated when starting it at low temperatures.



Engine failure indicator



The Compact 5.0 ton model

The compact 5.0 ton model features a shorter wheelbase and swift mobility while maintaining the power and speed capable of achieving high productivity.



Advanced Design in Pursuit of "Safety and Comfort"

Effective Safety Mechanisms

"Operator Presence Sensing system"

The Operator Presence Sensing system incorporates a Lifting/Traveling interlocking function. This is a safety function for disabling traveling and lifting mechanisms when the operator is not correctly occupying the seat. An alarm buzzer sounds if the operator leaves the seat while traveling.

*The traveling interlocking function only disengages traction and does not automatically apply the brakes.
* Operator Presence Sensing system: ISO3691-1 compliant



Lifting interlock lamp on the control panel



When the operator leaves the seat, Operator Presence Sensing system is activated

Parking Brake Alarm



A double action type brake lever prevents mishandling

A Wide Angle Center Mirror enables an Easy Rearview



A Neutral Start Function for Preventing a Sudden Start

The engine cannot be started unless the F-R switch is in the neutral position.



Neutral indicator for at-a-glance information

ISO-Compliant Enhanced Overhead Guard for Operator's Protection

A Safety Mechanism that prevents starting the engine unless the brake pedal is pressed



Secure Operation Controls Improve Operator Work Efficiency

Secure Lever Controls with Minimum Movement



Finger-tip operation with the electric F/R lever

A Smaller Steering Wheel Permits Widened Front Visibility

Use of a smaller steering wheel and redesign of the dashboard have improved the visibility of the bottom of the fork, thus further facilitating the lifting operation.

Steering wheel diameter: **300 mm**



Improved Brake Feeling

Komatsu's unique cushion valve enables control of the braking force in proportion to the pressure on the brake pedal and improves the brake feeling.



Control lever with an excellent hand fitting profile

Comfortable & Fatigue-Free Operation Even Over Long-Hour Operation

Dual Floating Structure Reduces Vibrations

A unique dual vibration cushioning mechanism reduces vibrations in the compartment, steering wheel, control levers and the mast. Any vibrations transmitted from the engine or road surface are quickly absorbed. The mechanism is friendly to both operator and load.



● **Suspension cab**
The entire cab is isolated from the frame.

● **Power train floating**
The engine and transmission are isolated from the frame.

New Suspension Seat

This seat is wide, offers waist support and thus enables the operator to sit in a relaxed state. An assist grip is mounted on the left side for easy getting on and off. Thus, provides comfortable work space and reduces operator's fatigue.

- Wide seat surface
- Orange seat belt
- Assist grip
- Seat position adjustment
- Seat reclining
- Seat suspension adjustment



Smooth Getting On/Off



Enlarged assist grip



Improved design of engine hood and step

Comfortable Reversing by Preventing Exposure to Hot Air/Exhaust Gas



Two counterweight air outlets are provided on the left and right sides and an exhaust pipe outlet is provided at a lower position so that the operator is not exposed to hot air from radiator or to exhaust gasses when reversing.



Exhaust outlet

The Low Noise Design

The low-noise design of the engine and the fully sealed floor reduce offending noise volumes during operation.

Clean Exhaust Air with a 3-Way Catalytic System (Gasoline)

The 3-way catalytic system purifies the nitrogen oxide (NOx), hydrocarbons (HC) and carbon monoxide (CO) emissions.

Careful Design Facilitates Inspection and Servicing

Easy Radiator Cleaning



Filter Layout Optimization for Improved Serviceability

A fully-opening floor plate.

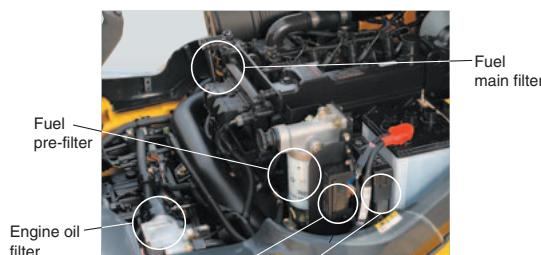

Fuel pre-filter

Engine oil filter

Fuel main filter

Fuse and relay boxes are arranged in the same location

Wide Opening Engine Hood with a Lock for Easy Servicing

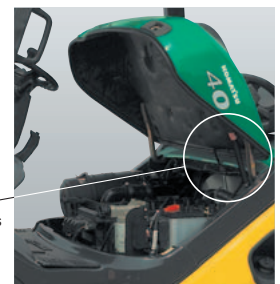

Engine hood locking provides safety servicing

Model



Compact model

This model is designed specifically for operating in restricted spaces. The load center is 500 mm.



Standard model

This model is designed to perform a broad range of general-purpose applications. The load center is 600 mm.

Optional Specification Truck

- **LPG specification truck**
Komatsu offers both single fuel (LPG) and dual fuel systems (LPG/Gasoline) for the LPG Specification truck.

Mast

- **2-stage free view mast**
The mast enables a wide view with excellent forward visibility.
- **2-stage full free view mast**
This is ideal for sites with height limitations, where the large free lift is required.
- **3-stage full free view mast**
The mast extends in three stages and high level loading is easily performed.

Attachments

- **Side shifter**
The fork may be shifted sideways together with its backrest, both to the right and to the left.
- **Fork positioner**
The operator is able to adjust the fork spread width from the operator's seat.
- **Hinged fork**
The fork tilts up/down using its hinge as a fulcrum.
- **Bale clamp**
This attachment is recommended for handling packed pulp or raw cotton. The bale is efficiently held from both sides by the bale clamps.
- **Rotating fork**
Used together with the fork inserted container, this attachment is used for transporting items such as powder, fluids, etc. The fork is rotated in order to discharge the load.
- **Roll clamp**
Rolls of paper or cylindrical objects are safely and securely handled by this attachment. It is possible to rotate the clamped load through 360 degrees.

Options

Engine & power train related

- Pre-cleaner
- Spark arrester
- Upward exhaust muffler
- Right forward/reverse lever
- Automatic transmission (4.5 & 5.0 t Diesel)

Exterior

- Canvas cabin
- Steel cabin
- Steel cabin with cooler (Diesel)
- Tilt cylinder boots
- Power steering cylinder protector plate
- Fuel cap with key (Diesel)
- Seat heater
- Front glass with wiper
- Rear view mirrors (pair)
- Resin overhead guard cover

Electrical equipment

- Back-up chime
- Mast mount type head lights
- Rear working light
- Yellow strobe light
- Red strobe light

Meters & gauges

- Load checker
- Mast tilt angle gauge
- Individual key switch
- Torque converter oil temperature gauge

Tyre-related

- Elastic cushion tyre
- Double front tyre



Steel cabin



Upward exhaust muffler



Front glass with wiper

Major equipment

●: Standard ○: Option -: N/A

		CX50 Series	
		Diesel	Gasoline/ LPG
CLSS (Closed-center Load Sensing System)		●	●
Wet disc brake		●	●
Engine-related	EPA Tier 3/EU Stage IIIA compliant Diesel engine	●	-
	EPA Tier 2 compliant Gasoline engine	-	●
	Electronic engine control system	●	●
	Heavy duty High Pressure Common Rail system	●	-
	New combustion system	●	-
	Air to air charge air cooling system	●	-
	Overheat prevention function	●	-
	Auto engine warm-up function	●	-
	Auto air pre-heat function	●	-
	3-way catalytic system	-	●
Traveling-related	Large capacity radiator	●	●
	Dual floating structure	●	●
	New operator's seat with suspension	●	●
	Small diameter steering wheel	●	●
	Tiltable steering column	●	●
	Electric forward/reverse lever	●	●
	Combination switch (turn signal light & light switch)	●	●
	Indicator auto-return mechanism	●	●
	Full-open step	●	●
	Paper binder at engine hood	●	●
Meters	Glove box at dashboard	●	●
	Meter panel	●	●
	Hourmeter (6-digit)	●	●
	Engine cooling water temperature gauge	●	●
	Torque converter oil temperature gauge	○	○
Indicators	Fuel gauge	●	●
	Lifting interlock lamp	●	●
	Engine oil pressure warning lamp	●	●
	Charge warning lamp	●	●
	Neutral indicator	●	●
	Failure indicator	●	●
	Engine failure indicator	●	●
	Brake fluid pressure warning buzzer	●	●
Electric components	Glow indicator	●	-
	Large capacity alternator	●	●
	Quick auto glow system	●	-
	Neutral start function	●	●
	Auto fuse	●	●
	Low maintenance battery	●	●
	Engine key stop function	●	-
	Halogen headlight	●	●
	Rear combination light	●	●
Back-up buzzer	●	●	
Mechanism	Operator Presence Sensing system	●	●
	Sedimenter with priming pump	●	-
	Cyclone air cleaner (double element)	●	●
	Parking brake with release button	●	●
	Fully hydrostatic power steering	●	●
	Steering knob synchronizer function	●	●
	Non-asbestos parking brake linings	●	●
	Key-off lift lock	●	●
Exterior	Floor mat	●	●
	Assist grip	●	●
	Overhead guard with front/rear conduits	●	●
	Wide angle center mirror	●	●
	Rear view mirrors (pair)	○	○
	Full shield solid-state engine hood	●	●
	Easy-removable floor panel	●	●
	Easy-removable radiator cover	●	●
	Engine hood lock	●	●
	Radiator reservoir tank	●	●
Resin dashboard cover	●	●	
Jacking points	●	●	

CX50 Series Specifications

Characteristics	1.2 Model		Manufacturer's Designation		FD40ZT-10	FD40T-10	FD45T-10	
	1.3 Power Type	Electric, Diesel, Gasoline, LPG, Cable				Diesel	Diesel	Diesel
1.4 Operation Type					Sitting	Sitting	Sitting	
1.5 Rated Capacity	Q	Rated Capacity		kg	4000	4000	4500	
1.6 Load Center	c	Rated Load Center		mm	500	600	600	
1.8 Load Distance	x	Front Axle Center to Fork Face		mm	540	580	590	
1.9 Wheelbase	y			mm	1800	2000	2000	
Weight	2.1 Service Weight				kg	5735	6270	6855
	2.2 Axle Loading	Loaded	Front	kg	8575	8920	9950	
			Rear	kg	1160	1350	1405	
		Unloaded	Front	kg	2260	2560	2770	
			Rear	kg	3475	3710	4085	
Tyres	3.1 Tyre Type				Pneumatic	Pneumatic	Pneumatic	
	3.2 Tyre Size	Front			250-15-16PR(I)	300-15-18PR(I)	300-15-18PR(I)	
		Rear			7.00-12-12PR(I)	7.00-12-12PR(I)	7.00-12-14PR(I)	
	3.5 Number of Wheel		Front/Rear (x=driven)			2x/2	2x/2	2x/2
	3.6 Tread, Front	b10			mm	1115	1150	1150
3.7 Tread, Rear	b11			mm	1120	1120	1120	
Dimensions	4.1 Tilting Angle	α / β	Forward/Backward		degree	6/12	6/12	6/12
	4.2 Mast Height, Lowered	h1	2-stage Mast		mm	2100	2105	2205
	4.3 Std. Free Lift	h2	2-stage Std. Mast, from Ground		mm	155	160	145
	4.4 Std. Lift Height	h3	2-stage Std. Mast, from Ground		mm	3000	3000	3000
	4.5 Mast Height, Extended	h4	2-stage Std. Mast		mm	4130	4130	4130
	4.7 Height, Overhead Guard	h6			mm	2210	2250	2250
	4.19 Length, with Std. Forks	L1			mm	4025	4220	4270
	4.20 Length, to Fork Face	L2			mm	2955	3150	3200
	4.21 Width, at Tyre	b1	Single		mm	1350	1450	1450
	4.22 Forks	s/e/l	Thickness x Width x Length		mm	50 x 150 x 1070	55 x 150 x 1070	55 x 150 x 1070
	4.23 Fork Carriage Class	ISO 2328, Type A/B/no				Class3, A	Class3, A	Class3, A
	4.24 Width, Fork Carriage	b3			mm	1190	1190	1190
	4.31 Ground Clearance	m1	Under Mast		mm	140	145	145
		m2	at Center of Wheelbase		mm	175	220	220
	4.33 Right Angle Stacking Aisle	Ast	with L1000 x W1200 pallet		mm	4190	4420	4480
Ast		with L1200 x W800 pallet		mm	4320	4550	4610	
4.35 Turning Radius	Wa			mm	2580	2770	2820	
Performance	5.1 Travel Speed (FWD)	Loaded, 1st/2nd		km/h	18.0/-	18.0/-	14.5/24.0	
		Unloaded, 1st/2nd		km/h	19.0/-	19.0/-	15.5/25.0	
	5.2 Lifting Speed	Loaded		mm/s	540	540	470	
		Unloaded		mm/s	560	560	480	
	5.3 Lowering Speed	Loaded		mm/s	500	500	500	
		Unloaded		mm/s	500	500	500	
	5.6 Max. Drawbar Pull	Loaded 1.5 km/h, 3 min rating		kN	27	27	33	
	5.8 Max. Gradeability	Loaded 1.5 km/h, 3 min rating		%	30	28	29	
	5.10 Service Brake	Operation/Type				Foot/Hydraulic	Foot/Hydraulic	Foot/Hydraulic
	5.11 Parking Brake	Operation/Control				Hand/Mechanical	Hand/Mechanical	Hand/Mechanical
5.12 Steering	Type				FHPS	FHPS	FHPS	
6.4 Battery	Voltage/Capacity at 5-hour rating		V/Ah	12/64	12/64	12/64		
I.C Engine	7.1 Make					KOMATSU	KOMATSU	KOMATSU
	7.1 Model					SAA4D95LE-5-A	SAA4D95LE-5-A	SAA4D95LE-5-A
	7.2 Rated Output, SAE net			kW		59.7	59.7	59.7
	7.3 Rated RPM			min ⁻¹		2400	2400	2400
	7.3.1 Max. Torque, SAE net			Nm@min ⁻¹		321@1600	321@1600	321@1600
	7.4 No. of Cylinder/Displacement			cm ³		4-3260	4-3260	4-3260
7.6 Fuel Tank Capacity			L		76	98	98	
Others	8.2 Relief Pressure for Attachment				MPa	20.6	20.6	20.6
	8.2.1 Hydraulic tank Capacity				L	55	72	72
	8.7 Transmission						TORQFLOW	TORQFLOW

Dimensions

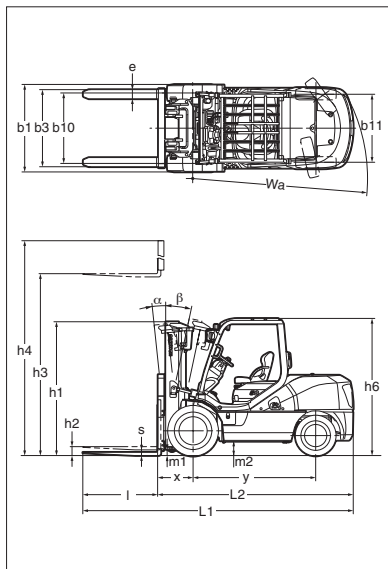

Right angle stacking aisle width

model	Length of pallet (mm)	Width of pallet (mm)						
		800	900	1000	1100	1200	1300	1400
FD40Z FG40Z	800	4190	4190	4190	4190	4190	4190	4190
	900	4190	4190	4190	4190	4190	4190	4190
	1000	4190	4190	4190	4190	4190	4190	4190
	1100	4220	4220	4220	4220	4220	4220	4220
	1200	4320	4320	4320	4320	4320	4320	4320
	1300	4420	4420	4420	4420	4420	4420	4420
FD40 FG40	1400	4520	4520	4520	4520	4520	4520	4520
	800	4375	4375	4375	4375	4375	4375	4375
	900	4375	4375	4375	4375	4375	4375	4375
	1000	4375	4375	4375	4375	4375	4375	4375
	1100	4405	4405	4405	4405	4405	4405	4405
	1200	4505	4505	4505	4505	4505	4505	4505
FD45 FG45	1300	4605	4605	4605	4605	4605	4605	4605
	1400	4705	4705	4705	4705	4705	4705	4705
	800	4645	4645	4645	4645	4645	4645	4645
	900	4645	4645	4645	4645	4645	4645	4645
	1000	4645	4645	4645	4645	4645	4645	4645
	1100	4645	4645	4645	4645	4645	4645	4645
FD50A FG50A	1200	4645	4645	4645	4645	4645	4645	4645
	1300	4725	4725	4725	4725	4725	4725	4725
	1400	4825	4825	4825	4825	4825	4825	4825
	800	4420	4420	4420	4420	4420	4420	4420
	900	4420	4420	4420	4420	4420	4420	4420
	1000	4420	4420	4420	4420	4420	4420	4420
FD50A FG50A	1100	4450	4450	4450	4450	4450	4450	4450
	1200	4550	4550	4550	4550	4550	4550	4550
	1300	4650	4650	4650	4650	4650	4650	4650
	1400	4750	4750	4750	4750	4750	4750	4750

Aisle Width shown in this table are not inclusive any operational clearance.

FD50AT-10	FG40ZT-10	FG35T-10	FG40T-10	FG45T-10	FG50AT-10
Diesel	Gasoline	Gasoline	Gasoline	Gasoline	Gasoline
Sitting	Sitting	Sitting	Sitting	Sitting	Sitting
5000	4000	3500	4000	4500	5000
600	500	600	600	600	600
575	540	575	580	590	575
2000	1800	2000	2000	2000	2000
7295	5685	5740	6215	6800	7240
10820	8530	8080	8885	9915	10785
1475	1155	1160	1330	1385	1455
2885	2215	2525	2525	2735	2850
4410	3470	3215	3690	4065	4390
Pneumatic	Pneumatic	Pneumatic	Pneumatic	Pneumatic	Pneumatic
300-15-18PR(I)	250-15-16PR(I)	8.25-15-12PR(I)	300-15-18PR(I)	300-15-18PR(I)	300-15-18PR(I)
7.00-12-14PR(I)	7.00-12-12PR(I)	7.00-12-12PR(I)	7.00-12-12PR(I)	7.00-12-14PR(I)	7.00-12-14PR(I)
2x/2	2x/2	2x/2	2x/2	2x/2	2x/2
1150	1115	1115	1150	1150	1150
1120	1120	1120	1120	1120	1120
6/12	6/12	6/12	6/12	6/12	6/12
2205	2100	2105	2105	2205	2205
145	155	155	160	145	145
3000	3000	3000	3000	3000	3000
4345	4130	4130	4130	4130	4345
2250	2210	2250	2250	2250	2250
4405	4025	4155	4220	4270	4405
3185	2955	3085	3150	3200	3185
1450	1350	1350	1450	1450	1450
55 x150 x1220	50 x 150 x 1070	50 x150 x1070	55 x 150 x 1070	55 x 150 x 1070	55 x 150 x 1220
Class4, A	Class3, A	Class3, A	Class3, A	Class3, A	Class4, A
1270	1190	1190	1190	1190	1270
145	140	145	145	145	145
220	175	225	220	220	220
4645	4190	4375	4420	4480	4645
4645	4320	4505	4550	4610	4645
2850	2580	2730	2770	2820	2850
14.5/24.0	18.0/-	18.0/-	18.0/-	15.5/23.0	14.5/23.5
15.5/25.0	19.0/-	19.0/-	19.0/-	16.5/24.0	15.5/24.5
470	510	510	510	440	440
480	510	510	510	440	440
500	500	500	500	500	500
500	500	500	500	500	500
33	24	24	24	28	28
28	28	25	25	26	25
Foot/Hydraulic	Foot/Hydraulic	Foot/Hydraulic	Foot/Hydraulic	Foot/Hydraulic	Foot/Hydraulic
Hand/Mechanical	Hand/Mechanical	Hand/Mechanical	Hand/Mechanical	Hand/Mechanical	Hand/Mechanical
FHPS	FHPS	FHPS	FHPS	FHPS	FHPS
12/64	12/38	12/38	12/38	12/38	12/38
KOMATSU	GCT	GCT	GCT	GCT	GCT
SAA4D95LE-5-A	EBT-GK45-1A*	EBT-GK45-1A*	EBT-GK45-1A*	EBT-GK45-1A*	EBT-GK45-1A*
59.7	62.5	62.5	62.5	62.5	62.5
2400	2400	2400	2400	2400	2400
321@1600	272@1600	272@1600	272@1600	272@1600	272@1600
4-3260	6-4451	6-4451	6-4451	6-4451	6-4451
98	76	98	98	98	98
20.6	20.6	20.6	20.6	20.6	20.6
72	55	72	72	72	72
TORQFLOW	TORQFLOW	TORQFLOW	TORQFLOW	TORQFLOW	TORQFLOW

Note*: EBT-GK45-1A for Gasoline, EBT-GK45-2A for Gasoline/LPG, EBT-GK45-3A for LPG specification.

■ **Maximum load and overall height of mast by lifting height** (2-stage free view mast, single tyre, load center 600 mm/ * load center 500 mm)

maximum fork height (mm)	model	Load capacity (kg)					Overall height [Lowered / Extended**] (mm)			
		FD(G)40Z*	FG35	FD(G)40	FD(G)45	FD(G)50A	FD(G)40Z*	FD(G)35/40	FD(G)45	FD(G)50
3000		4000	3500	4000	4500	5000	2100/4130	2105/4130	2205/4130	2205/4355
3500		4000	3500	4000	4500	5000	2350/4630	2355/4630	2455/4630	2455/4845
4000		4000	3500	4000	4500	5000	2650/5130	2655/5130	2755/5130	2755/5345
4300		4000	3500	4000	4500	5000	2800/5430	2805/5430	2905/5430	2905/5645
4500		4000	3500	4000	4500	5000	2900/5630	2905/5630	3005/5630	3005/5845
4700		3700	2800	4000	4000	4000	3050/5830	3055/5830	3155/5830	3155/6045
5000		3700	2800	4000	4000	4000	3200/6130	3205/6130	3305/6130	3305/6345
5500		2600	2100	3200	3000	2900	3450/6630	3455/6630	3555/6630	3555/6845
6000		1900	1600	2400	2200	2200	3700/7130	3705/7130	3805/7130	3805/7345

** With standard load backrest

■ **Load capacity curve**

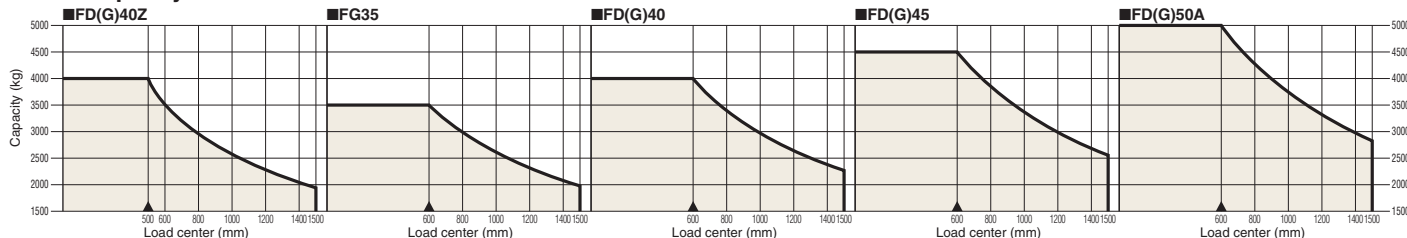

<https://home.komatsu/en/>

Printed in Japan 201803shi

KOMATSU[®]

Form No. BR-CX50emi-002

Materials and specifications are subject to change without notice
KOMATSU is a trademark of Komatsu Ltd. Japan